

# 1. JY-6311 Specifications

## 1.1 Overview



The JY-6311 is an advanced channel-to-channel isolated RTD temperature measurement module. The JY-6311 supports 16 channels with 2-wire, 3-wire, and 4-wire configurations, catering to a variety of sensor and transducer requirements. Key features include a 24-bit ADC resolution for detailed data capture, a wide temperature measurement range suitable for PT100 (-200°C to +850°C) sensor, and a high sampling rate of 800 Sa/s for rapid data acquisition. The input channels are isolated, enhancing safety and noise immunity, making the JY-6311 ideal for demanding industrial settings. It is designed to serve a broad spectrum of scientific and industrial applications with its robust capabilities.

🔗 Please download JYTEK <[JYPEDIA](#)>, you can quickly inquire the product prices, the key features and available accessories.

## 1.2 Main Features

- High accuracy : 200 ppm
- 16 channels' RTD measurement supporting 2-wire, 3-wire, and 4-wire configurations
- 24-bit ADC resolution
- -200 °C to +850 °C temperature measurement range for PT100 sensors
- Channel-to-channel Isolation
- 800 Sa/s maximum sampling rate
- 50/60 Hz noise rejection and High Common Mode Reiection Ratio
- 0.07°C absolute measurement accuracy for 4-wire mode

## 1.3 Hardware Specifications

### 1.3.1 Input Characteristics

Number of channels	16ch (2-wire/3-wire/4-wire)
Sampling mode	Simultaneous sampling
Sensor support	RTD PT100
ADC resolution	24 bits
ADC type	$\Delta$ - $\Sigma$
Input isolation	Yes
Sampling rate	Max 800 Sample/s per channel
Clock	Onboard (25 MHz) PXIe_CLK100
Storage depth	128M Samples
Measuring range	0 $\Omega$ ~ 400 $\Omega$ / -200 $^{\circ}\text{C}$ ~ +850 $^{\circ}\text{C}$ (for PT100)
Terminal type	2-wire/3-wire/4-wire
Excitation current	1 mA (PT100)
Trigger type	Digital/Software
Trigger mode	StartTrigger, ReferenceTrigger, ReTrigger
Digital trigger source	PXI_TRIG <0..7> PFI<0..2>

Table 1 Input Characteristics

### 1.3.2 Measuring Range

Temperature measurement range	-200 $^{\circ}\text{C}$ ~ +850 $^{\circ}\text{C}$
Resistance measurement range	0 $\Omega$ ~ 400 $\Omega$
Excitation current	1 mA
DC linearity	$\pm 15$ ppm max
Channel-to-earth isolation	$\pm 60$ VDC

Table 2 Measuring Range

### 1.3.3 Basic Resistance Accuracy

JY-6311 Accuracy = $\pm(\text{Gain Error \% of Reading} + \text{Offset Error m}\Omega)$ ,4-Wire										
Range ( $\Omega$ )	24 Hour Tcal $\pm 1^{\circ}\text{C}$	90 Days Tcal $\pm 5^{\circ}$	24 Hr Accuracy @100 $\Omega$	90 Days Accuracy @100 $\Omega$	24 Hr Full Scale Accuracy @400 $\Omega$	90 Days Full Scale Accuracy @400 $\Omega$	24 Hr Full Scale Accuracy @400 $\Omega$ (%)	90 Days Full Scale Accuracy @400 $\Omega$ (%)	2,3-wire Offset Adjustment	
400	0.004 + 0.004	0.010 + 0.010	16 m $\Omega$	50 m $\Omega$	25 m $\Omega$	80 m $\Omega$	0.006	0.020	1 m $\Omega$	

SampleRate = 40/400/800 Samples/second

Table 3 Resistance measurement accuracy

JY-6311 Additional Accuracy Adjustment = $\pm(\% \text{ Reading} + \% \text{ Range})$		
Range ( $\Omega$ )	Temperature Coefficients (/ $^{\circ}\text{C}$ )	Full-Scale Temp Adjustment ( $\text{m}\Omega / ^{\circ}\text{C}$ )
400	0.00083 + 0.00003	3.5 $\text{m}\Omega$
SampleRate = 40/400/800 Samples/second		

Table 4 Resistance measurement additional accuracy adjustment

### 1.3.4 Temperature Measurement Accuracy

JY-6311 Temperature Measurement Accuracy			
RTD Type	Temperature Range ( $^{\circ}\text{C}$ )	24H Temperature Measurement Accuracy (4-Wire) ( $^{\circ}\text{C}$ )	90Days Temperature Measurement Accuracy (4-Wire) ( $^{\circ}\text{C}$ )
PT 100	-200 to 850	0.11	0.27
SampleRate = 40/400/800 Samples/second			

Table 5 Temperature measurement accuracy

### 1.3.5 Input Protection

Overvoltage protection (between AI- and EX-)	$\pm 5 \text{ V}$
Overvoltage protection (between AI+/EX+, AI+/EX-, AI-/EX+, AI-/AI-, EX+/EX-)	$\pm 15 \text{ V}$
Overvoltage protection (any pin to Ground):	$\pm 60 \text{ V}$

Table 6 Input Protection

### 1.3.6 Isolation Voltages

Channel-to-channel	$\pm 60 \text{ V}$
Channel-to-earth	Continuous : 60 VDC, Measurement Category I Withstand : 1,000 Vrms, verified by a 5 s dielectric withstand test

Table 7 Safety Voltages

### 1.3.7 CMRR

Rejection of channel-to-channel common mode voltages	
Sample Rate $\leq 40 \text{ S/s}$ , best 50/60 Hz rejection	180 dB
Sample Rate $> 40 \text{ S/s}$	128 dB
Rejection of channel-to-earth ground common mode voltages	
Sample Rate $\leq 40 \text{ S/s}$ , best 50/60 Hz rejection	180 dB
Sample Rate $> 40 \text{ S/s}$	128 dB

Table 8 Digital trigger

### 1.3.8 Trigger

#### Digital trigger

Trigger source	PXI_TRIG <0..7>, PFI <0..2>
Trigger mode	Start Trigger, Reference Trigger
Trigger polarity	Software-selectable

Table 9 Digital trigger

### 1.3.9 Clocking

Reference Clock Source	Onboard Clock, PXIe_Clk100 (RefClk only)
Sample Clock Source	Internal, PXI_Trig, PFI

Table 10 clocking

### 1.3.10 Bus Interface

Form factor (PXIe)	3U PXI Express peripheral module
Form factor (PCIe)	PCIe Gen2 × 4
Slot compatibility (PXIe)	x1 and x4 PXI Express or PXI Express hybrid slots

Table 11 Bus Interface

### 1.3.11 Power Requirement

+3.3 V	500 mA
+12 V	600 mA

Table 12 Power Requirement

### 1.3.12 Physical and Environment

#### Physical Characteristics

Weight	145 g
I/O connector	VHDCI 68-Pin

Table 13 Physical Characteristics

#### Environment

Maximum altitude	2,000 m (800 mbar) (at 25 °C ambient temperature)
Pollution Degree	2

Table 14 Environment

## Operating Environment

Ambient temperature range	0 °C to 50 °C
Relative humidity range	10% to 90%, noncondensing

Table 15 Operating Environment

## Storage Environment

Ambient temperature range	-40 °C to 71 °C
Relative humidity range	5% to 95%, noncondensing

Table 16 Storage Environment

## 2. Order Information

- PXIe-6311 (PN: JY1029597-01)  
16-ch 24-bit PXIe ch-to-ch isolated RTD temperature input module
- PCIe-6311 (PN: JY5439902-01)  
16-ch 24-bit PCIe ch-to-ch isolated RTD temperature input module
- Accessories:

Cable:

ACL-1016868-1 1M 68pin VHDC-SCSI twisted pair cable (PN: JY7996916-01)

ACL-1016868-2 2M 68pin VHDCI-SCSI twisted pair cable (PN: JY7996916-02)

Terminal Block:

TB-68 68-Pin SCSI Shielded I/O Connector Block (PN: JY2000068-04)

DIN-68 SCSI 68-pin Terminal board (PN: JY1717615-01)

## Table of Contents

<b>1.JY-6311 Specifications</b>	<b>1</b>
1.1 Overview	1
1.2 Main Features	1
1.3 Hardware Specifications	2
1.3.1 Input Characteristics	2
1.3.2 Measuring Range	2
1.3.3 Basic Resistance Accuracy	2
1.3.4 Temperature Measurement Accuracy	3
1.3.5 Input Protection	3
1.3.6 Isolation Voltages	3
1.3.7 CMRR	3
1.3.8 Trigger	4
1.3.9 Clocking	4
1.3.10 Bus Interface	4
1.3.11 Power Requirement	4
1.3.12 Physical and Environment	4
<b>2.Order Information</b>	<b>5</b>
<b>3.Introduction</b>	<b>9</b>
3.1 Abbreviations	9
3.2 JYPEDIA and Learn by Example	9
<b>4.Hardware Specifications</b>	<b>10</b>
4.1 Front Panel	10
4.2 Pin Definition	11
4.3 RTD Connections	12
4.3.1 2-Wire RTD connection	12
4.3.2 3-Wire RTD connection	12
4.3.3 4-wire RTD connection	13
<b>4.4 Resistance Measurement Accuracy</b>	<b>14</b>
4.4.1 Gain and Offset Error	14
4.4.2 Basic Resistance Accuracy	14
4.4.3 Example of Calculating Gain and Offset Errors	14
<b>4.5 Temperature Measurement Accuracy</b>	<b>15</b>
4.5.1 RTD Measurement Basics	15
4.5.2 RTD Accuracy	15
4.5.3 Temperature Measurement Accuracy by JY-6311	16
4.5.4 Total Temperature Measurement Accuracy	16
<b>5.Software</b>	<b>17</b>
5.1 System Requirements	17
5.2 System Software	17
5.3 C# Programming Language	17
5.4 JY-6311 Series Hardware Driver	17

5.5 Install the SeeSharpTools from JYTEK .....	18
5.6 Running C# Programs in Linux .....	18
<b>6. Calibration .....</b>	<b>19</b>
<b>7. Using JY-6311 in Other Software .....</b>	<b>19</b>
7.1 Python .....	19
7.2 C++ .....	19
7.3 LabVIEW.....	19
<b>8. Appendix.....</b>	<b>20</b>
8.1 PT100 Temperature/Resistance Table .....	20
<b>9. About JYTEK .....</b>	<b>22</b>
9.1 JYTEK China .....	22
9.2 JYTEK Software Platform.....	22
9.3 JYTEK Warranty and Support Services .....	22
<b>10. Statement .....</b>	<b>23</b>
<b>Table 1 Input Characteristics .....</b>	<b>2</b>
<b>Table 2 Measuring Range .....</b>	<b>2</b>
<b>Table 3 Resistance measurement accuracy.....</b>	<b>2</b>
<b>Table 4 Resistance measurement additional accuracy adjustment .....</b>	<b>3</b>
<b>Table 5 Temperature measurement accuracy .....</b>	<b>3</b>
<b>Table 6 Input Protection .....</b>	<b>3</b>
<b>Table 7 Safety Voltages.....</b>	<b>3</b>
<b>Table 8 Digital trigger .....</b>	<b>3</b>
<b>Table 9 Digital trigger .....</b>	<b>4</b>
<b>Table 10 clocking.....</b>	<b>4</b>
<b>Table 11 Bus Interface .....</b>	<b>4</b>
<b>Table 12 Power Requirement .....</b>	<b>4</b>
<b>Table 13 Physical Characteristics .....</b>	<b>4</b>
<b>Table 14 Environment .....</b>	<b>4</b>
<b>Table 15 Operating Environment.....</b>	<b>5</b>
<b>Table 16 Storage Environment.....</b>	<b>5</b>
<b>Table 17 JY-6311 Connector.....</b>	<b>11</b>
<b>Table 18 Signal Description .....</b>	<b>11</b>
<b>Table 19 Basic Resistance Accuracy .....</b>	<b>14</b>
<b>Table 20 Calculating Gain and Offset Errors.....</b>	<b>14</b>
<b>Table 21 JY-6311 Temperature Measurement Accuracy.....</b>	<b>15</b>
<b>Table 22 Err1: RTD Tolerance Class Information.....</b>	<b>16</b>
<b>Table 23 Calculating Total Error .....</b>	<b>16</b>
<b>Table 24 Supported Linux Versions.....</b>	<b>17</b>
<b>Table 25 PT100 Temperature/Resistance Index Table .....</b>	<b>20</b>
<b>Table 26 PT100 Temperature/Resistance Index Table (continued from the previous table) .....</b>	<b>21</b>

**Figure 1 JYPEDIA Information..... 9**  
**Figure 2 JY-6311 Front Panel ..... 10**  
**Figure 3 2-wire RTD connection..... 12**  
**Figure 4 3-wire RTD connection..... 13**  
**Figure 5 4-wire RTD connection..... 13**  
**Figure 6 RTD Temperature Measurement Principle ..... 15**



### 3. Introduction

#### 3.1 Abbreviations

- AI: Analog Input
- ADC: Analog to Digital Converter
- PFI: Programmable Function Interface
- RTD: Resistance Temperature Detector
- Ex+: Positive terminal of current Excitation
- Ex-: Negative terminal of current Excitation
- RDC: Resistance-to-Digital Converter
- OS: Operating System
- CMRR: Common-mode rejection ratio

#### 3.2 JYPEDIA and Learn by Example

We provide many sample programs for this device. Please download the sample programs for this device. You can download a [JYPEDIA](#) excel file from our web [www.jytek.com](http://www.jytek.com). Open JYPEDIA and search for JY-6311 in the driver sheet, select **JY6311 Examples.zip**. In addition to the download information, JYPEDIA also has a lot of other valuable information, JYTEK highly recommend you use this file to obtain information from JYTEK.



Drivers	Update Date	Category	Support Module
<a href="#">JY6311 V1.0.0 Win.tar</a>	2024/5/10	Driver	6311
<a href="#">JY6311 V1.0.0 C++Examples.rar</a>	2024/5/10	Example	6311
<a href="#">JY6311 V1.0.0 Examples.rar</a>	2024/5/10	Example	6311
<a href="#">JY6311 V1.0.0 Linux.tar</a>	2024/5/10	Driver	6311

Figure 1 JYPEDIA Information

## 4. Hardware Specifications

### 4.1 Front Panel

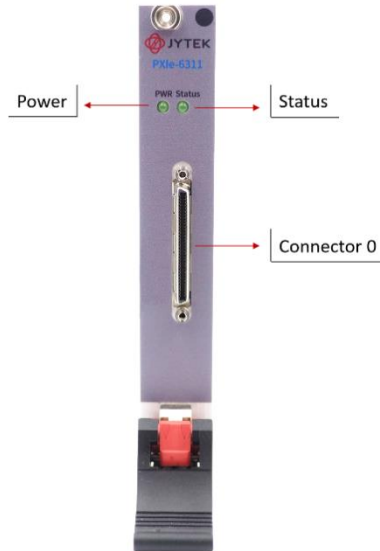

Figure 2 JY-6311 Front Panel

## 4.2 Pin Definition

Pin	Signal	4-Wire	3-Wire	2-Wire	Pin	Signal	4-Wire	3-Wire	2-Wire
1	AI0-	√	√		35	AI0+	√		
2	EX0-	√	√	√	36	EX0+	√	√	√
3	AI1-	√	√		37	AI1+	√		
4	EX1-	√	√	√	38	EX1+	√	√	√
5	AI2-	√	√		39	AI2+	√		
6	EX2-	√	√	√	40	EX2+	√	√	√
7	AI3-	√	√		41	AI3+	√		
8	EX3-	√	√	√	42	EX3+	√	√	√
9	AI4-	√	√		43	AI4+	√		
10	EX4-	√	√	√	44	EX4+	√	√	√
11	AI5-	√	√		45	AI5+	√		
12	EX5-	√	√	√	46	EX5+	√	√	√
13	AI6-	√	√		47	AI6+	√		
14	EX6-	√	√	√	48	EX6+	√	√	√
15	AI7-	√	√		49	AI7+	√		
16	EX7-	√	√	√	50	EX7+	√	√	√
17	AI8-	√	√		51	AI8+	√		
18	EX8-	√	√	√	52	EX8+	√	√	√
19	AI9-	√	√		53	AI9+	√		
20	EX9-	√	√	√	54	EX9+	√	√	√
21	AI10-	√	√		55	AI10+	√		
22	EX10-	√	√	√	56	EX10+	√	√	√
23	AI11-	√	√		57	AI11+	√		
24	EX11-	√	√	√	58	EX11+	√	√	√
25	AI12-	√	√		59	AI12+	√		
26	EX12-	√	√	√	60	EX12+	√	√	√
27	AI13-	√	√		61	AI13+	√		
28	EX13-	√	√	√	62	EX13+	√	√	√
29	AI14-	√	√		63	AI14+	√		
30	EX14-	√	√	√	64	EX14+	√	√	√
31	AI15-	√	√		65	AI15+	√		
32	EX15-	√	√	√	66	EX15+	√	√	√
33	PFI1	√	√	√	67	PFI0	√	√	√
34	GND	√	√	√	68	PFI2	√	√	√

Table 17 JY-6311 Connector

Signal Type	Description
AI+	Resistance measurement high side
AI-	Resistance measurement low side
EX+	Positive terminal of current excitation
EX-	Negative terminal of current excitation

Table 18 Signal Description

## 4.3 RTD Connections

JY-6311 can support 2-wire, 3-wire or 4-wire RTD connection.

### 4.3.1 2-Wire RTD connection

When using a 2-wire RTD configuration, user needs to connect the RTD signal to Ex+ and Ex- terminal of current excitation as shown in Figure 3. Due to the presence of lead wires resistance, this type of connection may introduce large measurement errors, which are related to the material of the lead wire. This type of wiring is not suitable for high precision temperature measurement needs.

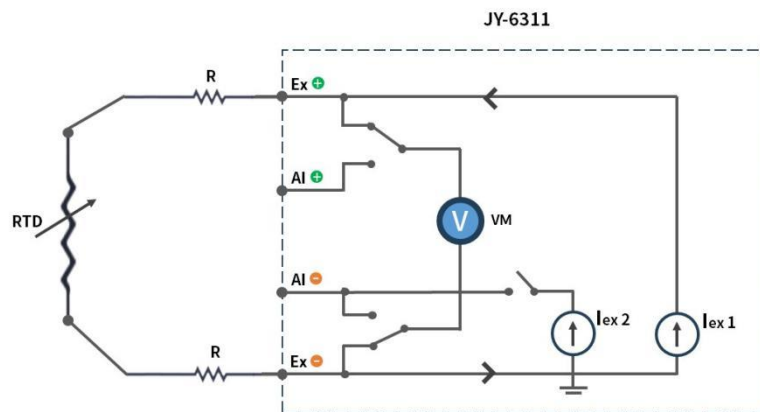

Figure 3 2-wire RTD connection

### 4.3.2 3-Wire RTD connection

In a 3-wire RTD configuration, the Ex+ and AI- terminal will output two precision current excitations to the RTD sensor and flow back through the Ex- terminal as shown in Figure 4.

Since the voltage generated by the wire resistance connected to the Ex+ terminal and the voltage of wire resistance connected to the AI- terminal will cancel each other out, this type of connection effectively eliminates the effect of wire resistance, but in practice, it is difficult to match the resistances of the two wires exactly, so there will still be some degree of mismatch error.

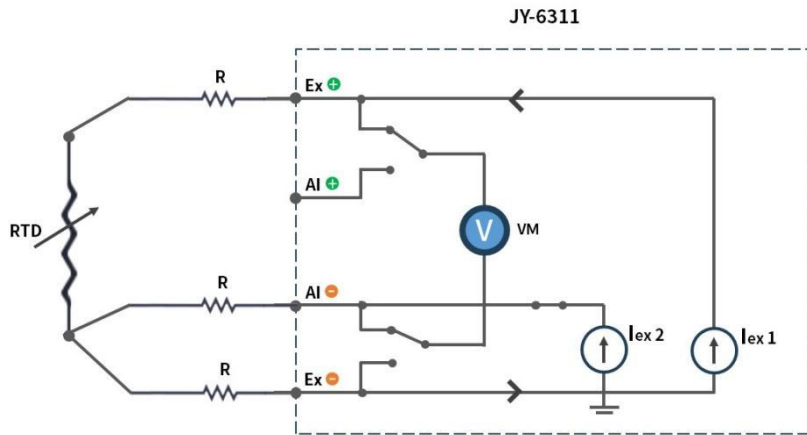

Figure 4 3-wire RTD connection

### 4.3.3 4-wire RTD connection

In a 4-wire configuration, the Ex+ terminal will output a 1 mA excitation current which flows back to the Ex- terminal and measures only the voltage of the RTD as shown in Figure 5.

Since the current loop of the leads is independent of the voltage measurement circuit, there is no error due to lead resistance.

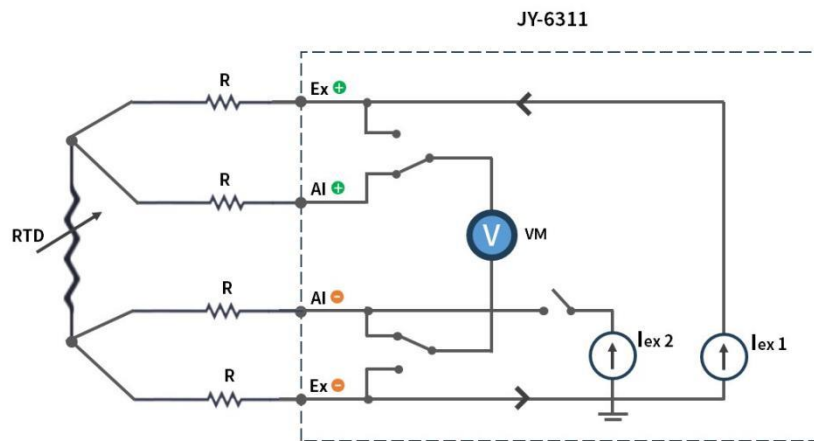

Figure 5 4-wire RTD connection

## 4.4 Resistance Measurement Accuracy

This chapter provides the voltage accuracy specifications of JY-6311

### 4.4.1 Gain and Offset Error

JY-6311 measures RTD resistance. It has built-in filters to improve the measurement accuracy of JY-6311 accuracy is defined by:

$$\text{Accuracy} = \text{Gain Error (\% of reading)} + \text{Offset Error (m}\Omega\text{)}.$$

It should be noted when the reading is close to zero, the gain error is very small and negligible, the offset error is dominant; when the reading is getting close to the full range, the gain error becomes more significant.

### 4.4.2 Basic Resistance Accuracy

The basic RTD measurement accuracy is shown in Table 19.

JY-6311 Accuracy = $\pm$ (Gain Error % of Reading + Offset Error m $\Omega$ ), 4-Wire										
Range ( $\Omega$ )	24 Hour Tcal $\pm$ 1C $^\circ$	90 Days Tcal $\pm$ 5 $^\circ$	24 Hr Accuracy @100 $\Omega$	90 Days Accuracy @100 $\Omega$	24 Hr Full Scale Accuracy @400 $\Omega$	90 Days Full Scale Accuracy @400 $\Omega$	24 Hr Full Scale Accuracy @400 $\Omega$ (%)	90 Days Full Scale Accuracy @400 $\Omega$ (%)	2,3-wire Offset Adjustment	
400	0.004 + 0.004	0.010 + 0.010	16 m $\Omega$	50 m $\Omega$	25 m $\Omega$	80 m $\Omega$	0.006	0.020	1 m $\Omega$	
SampleRate = 40/400/800 Samples/second										

Table 19 Basic Resistance Accuracy

Please refer to 4.3 for more information on 2,3 and 4-wire RTD connections.

### 4.4.3 Example of Calculating Gain and Offset Errors

Table 20 shows two examples of calculating the total gain and offset errors. Select the sample rate of 40 S/s and the range of 400  $\Omega$ . Then get two different measurements. The first one has a reading value of 100  $\Omega$ , while the second one has a reading value of 400  $\Omega$ . For the 100  $\Omega$  reading value, the gain error is 3 m $\Omega$ , while for the 400  $\Omega$  reading value, the gain error is 12 m $\Omega$ . The offset errors for both reading values are the same 28 m $\Omega$ . As a result, For the 100  $\Omega$  reading value, the total error(Gain+Offset) is 31 m $\Omega$ , while for the 400  $\Omega$ . reading value, the total error(Gain+Offset) is 40 m $\Omega$ .

Calculating Gain and Offset Errors				
Sample Rate (Sample/s)	40		40	
Error Calculation	Gain	Offset	Gain	Offset
Coef from Basic AccuracyTable (%)	0.003	0.007	0.003	0.007
Reading( $\Omega$ )and Range( $\Omega$ )	100	400	400	400
Gain and Offset Errors(m $\Omega$ )	3	28	12	28
Total Error (Gain+Offset)(m $\Omega$ )	31		40	

Table 20 Calculating Gain and Offset Errors

## 4.5 Temperature Measurement Accuracy

The temperature measurement is converted from the resistance measurement. The Table 5 lists the temperature measurement accuracies for different wire configurations.

JY-6311 Temperature Measurement Accuracy			
RTD Type	Temperature Range (°C)	24H Temperature Measurement Accuracy (4-Wire) (°C)	90Days Temperature Measurement Accuracy (4-Wire) (°C)
PT 100	-200 to 850	0.11	0.27
SampleRate = 40/400/800 Samples/second			

Table 21 JY-6311 Temperature Measurement Accuracy

### 4.5.1 RTD Measurement Basics

A platinum resistance temperature detector (RTD) has a typical resistance of 100 Ω at 0 °C. Its resistance varies with temperature, and it can typically measure temperatures up to 850°C. A RTD can be used to measure temperatures up to 850°C. It can also be used to measure temperatures up to 850°C. Letting current flow through the RTD produces a voltage across the RTD. By measuring this voltage, its resistance, and therefore its temperature, can be determined.

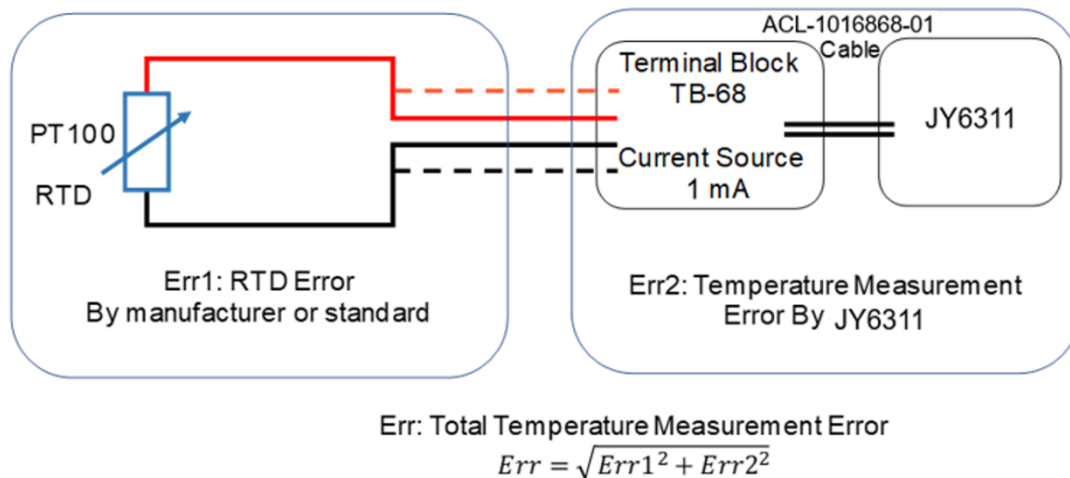

Figure 6 RTD Temperature Measurement Principle

This resistance is measured by JY-6311 and is then converted the temperature values using a conversion formula defined by the standard.

### 4.5.2 RTD Accuracy

A RTD has its own accuracy, also called the error tolerance in many international standards. Table 22 shows the accuracies of common RTD according to standards.

TOLERANCE	TOLERANCE VALUES(°C)	ERROR AT 100°C(°C)
ASTM Grade B	± (0.25 + 0.0042 •  T )	± 0.67
ASTM Grade A	± (0.13 + 0.0017 •  T )	± 0.3
IEC Class C	± (0.6 + 0.01 •  T )	± 1.6
IEC Class B	± (0.3 + 0.005 •  T )	± 0.8
IEC Class A	± (0.15 + 0.002 •  T )	± 0.35
IEC Class AA	± (0.1 + 0.0017 •  T )	± 0.27
1/10 DIN	± (0.03 + 0.0005 •  T )	± 0.8

Table 22 Err1: RTD Tolerance Class Information

The accuracies given by Table 22 are valid for unused RTD material only. It is important that users verify the accuracy of the RTD from the RTD manufacturer.

### 4.5.3 Temperature Measurement Accuracy by JY-6311

A RTD converts a temperature reading to a voltage which is then measured by JY-6311. The standard provides the conversion formula for different thermocouples and for different temperature ranges. Table 21 shows the temperature measurement accuracy using JY-6311 for each type and each range of RTD . The operating conditions are also listed in the table.

### 4.5.4 Total Temperature Measurement Accuracy

The total temperature measurement accuracy consists of the errors due to the RTD and measurement errors by JY-6311 as shown in Figure 6. It can be calculated by:

$$Total\ Accuracy\ Error = \sqrt{Err_1^2 + Err_2^2}$$

$Err_1$  is the RTD error from Table 22 of Section 4.5.2.  $Err_2$  is the temperature measurement accuracy from Table 21 of Section 4.5.3.

Table 23 shows two calculations for the total accuracies when using a IEC Class A RTD to measure 100° C and 800° C temperatures with 40 S/s sample rate. The two temperatures fall into different range. Hence the temperature measurement errors by JY-6311 are different.

Total Temperature Measurement Error (PT 100)		
Sample Rate (Sample/s)	40	
RTD Type and Class	PT 100	PT 100
Temperature Being Measured (°C)	100	800
Fixed Error from Standard IEC Class A( °C)	0.15	0.15
Calculated from Standard IEC Class A(  T  *0.002)(°C)	0.20	1.60
Err1: Total RTD Error for PT 100, Laraer of above two lines ( °C)	0.35	1.75
Err2: JY-6311 Temperature Measurement Accuracy for PT 100(°C)	0.27	0.27
Total Accuracy, sqrt(err1^2+err2^2)(°C)	0.44	1.77

Table 23 Calculating Total Error



## 5. Software

### 5.1 System Requirements

JY-6311 boards can be used in a Windows or a Linux operating system.

Microsoft Windows: Windows 7 32/64 bit, Windows 10 32/64 bit.

Linux Kernel Versions: There are many Linux versions. It is not possible JYTEK can support and test our devices under all different Linux versions. JYTEK will at the best support the following Linux versions.

Linux Version	
Ubuntu LTS	
16.04:	4.4.0-21-generic(desktop/server)
16.04.6:	4.15.0-45-generic(desktop) 4.4.0-142-generic(server)
18.04:	4.15.0-20-generic(desktop) 4.15.0-91-generic(server)
18.04.4:	5.3.0-28-generic (desktop) 4.15.0-91-generic(server)
Localized Chinese Version	
中标麒麟桌面操作系统软件（兆芯版）V7.0（Build61）: 3.10.0-862.9.1.nd7.zx.18.x86_64	
中标麒麟高级服务器操作系统软件V7.0U6: 3.10.0-957.el7.x86_64	

Table 24 Supported Linux Versions

### 5.2 System Software

When using the JY-6311 in the Window environment, you need to install the following software from Microsoft website:

Microsoft Visual Studio Version 2015 or above,

.NET Framework version is 4.0 or above.

.NET Framework is coming with Windows 10. For Windows 7, please check .NET Framework version and upgrade to 4.0 or later version.

Given the resources limitation, JYTEK only tested JY-6311 be with .NET Framework 4.0 with Microsoft Visual Studio 2015. JYTEK relies on Microsoft to maintain the compatibility for the newer versions.

### 5.3 C# Programming Language

All JYTEK default programming language is Microsoft C#. This is Microsoft recommended programming language in Microsoft Visual Studio and is particularly suitable for the test and measurement applications. C# is also a cross platform programming language.

### 5.4 JY-6311 Series Hardware Driver

After installing the required application development environment as described above, you need to install the JY-6311 hardware driver.

JYTEK hardware driver has two parts: the shared common driver kernel software (FirmDrive) and the specific hardware driver.

**Common Driver Kernel Software (FirmDrive):** FirmDrive is the JYTEK's kernel software for all hardware products of JYTEK instruments. You need to install the FirmDrive software before using any other JYTEK hardware products. FirmDrive only needs to be installed once. After that, you can install the specific hardware driver.

**Specific Hardware Driver:** Each JYTEK hardware has a C# specific hardware driver. This driver provides rich and easy-to-use C# interfaces for users to operate various JY-6311 function. JYTEK has standardized the ways which JYTEK and other vendor's DAQ boards are used by providing a consistent user interface, using the methods, properties and enumerations in the object-oriented programming environment. Once you get yourself familiar with how one JYTEK DAQ card works, you should be able to know how to use all other DAQ hardware by using the same methods.

Note that this driver does not support cross-process, and if you are using more than one function, it is best to operate in one process.

## 5.5 Install the SeeSharpTools from JYTEK

To efficiently and effectively use JY-6311 boards, you need to install a set of free C# utilities, SeeSharpTools from JYTEK. The SeeSharpTools offers rich user interface functions you will find convenient in developing your applications. They are also needed to run the examples come with JY-6311 hardware. Please register and download the latest SeeSharpTools from our website, [www.jytek.com](http://www.jytek.com).

## 5.6 Running C# Programs in Linux

Most C# written programs in Windows can be run by MonoDevelop development system in a Linux environment. You would develop your C# applications in Windows using Microsoft Visual Studio. Once it is done, run this application in the MonoDevelop environment. This is JYTEK recommended way to run your C# programs in a Linux environment.

If you want to use your own Linux development system other than MonoDevelop, you can do it by using our Linux driver. However, JYTEK does not have the capability to support the Linux applications. JYTEK completely relies upon Microsoft to maintain the cross-platform compatibility between Windows and Linux using MonoDevelop.

## 6. Calibration

JY-6311 Series boards are precalibrated before the shipment. We recommend you recalibrate JY-6311 board periodically to ensure the measurement accuracy. A commonly accepted practice is one year. If for any reason, you need to recalibrate your board, please contact JYTEK.

## 7. Using JY-6311 in Other Software

While JYTEK's default application platform is Visual Studio, the programming language is C#, we recognize there are other platforms that are either becoming very popular or have been widely used in the data acquisition applications. Among them are Python, C++ and LabVIEW. This chapter explains how you can use JY-6311 DAQ card using one of this software.

### 7.1 Python

JYTEK provides and supports a native Python driver for JY-6311 boards. There are many different versions of Python. JYTEK has only tested in CPython version 3.5.4. There is no guarantee that JYTEK python drivers will work correctly with other versions of Python.

If you want to be our partner to support different Python platforms, please contact us.

### 7.2 C++

We recommend our customers to use C# drivers because C# platform deliver much better efficiency and performance in most situations. We also provide C++ drivers and examples in the Qt IDE, which can be downloaded from web. However, due to the limit of our resources, we do not actively support C++ drivers. If you want to be our partner to support C++ drivers, please contact us.

### 7.3 LabVIEW

LabVIEW is a software product from National Instruments. JYTEK does not support LabVIEW and will no longer provide LabVIEW interface to JY-6311 boards. Our third-party partners may have LabVIEW support to JY-6311 boards. We can recommend you if you want to convert your LabVIEW applications to C# based applications.

## 8. Appendix

### 8.1 PT100 Temperature/Resistance Table

t(°C)	Resistance at temperature t(Ω)										t(°C)	
	0	-1	-2	-3	-4	-5	-6	-7	-8	-9		
-200	18.52											-200
-190	22.83	22.40	21.97	21.54	21.11	20.68	20.25	19.82	19.38	18.95		-190
-180	27.10	26.67	26.24	25.82	25.39	24.97	24.54	24.11	23.68	23.25		-180
-170	31.34	30.91	30.49	30.07	29.64	29.22	28.80	28.37	27.95	27.52		-170
-160	35.54	35.12	34.70	34.28	33.86	33.44	33.02	32.60	32.18	31.76		-160
-150	39.72	39.31	38.89	38.47	38.05	37.64	37.22	36.80	36.38	35.96		-150
-140	43.88	43.46	43.05	42.63	42.22	41.80	41.39	40.97	40.56	40.14		-140
-130	48.00	47.59	47.18	46.77	46.36	45.94	45.53	45.12	44.70	44.29		-130
-120	52.11	51.70	51.29	50.88	50.47	50.06	49.65	49.24	48.83	48.42		-120
-110	56.19	55.79	55.38	54.97	54.56	54.15	53.75	53.34	52.93	52.52		-110
-100	60.26	59.85	59.44	59.04	58.63	58.23	57.82	57.41	57.01	56.60		-100
-90	64.30	63.90	63.49	63.09	62.68	62.28	61.88	61.47	61.07	60.66		-90
-80	68.33	67.92	67.52	67.12	66.72	66.31	65.91	65.51	65.11	64.70		-80
-70	72.33	71.93	71.53	71.13	70.73	70.33	69.93	69.53	69.13	68.73		-70
-60	76.33	75.93	75.53	75.13	74.73	74.33	73.93	73.53	73.13	72.73		-60
-50	80.31	79.91	79.51	79.11	78.72	78.32	77.92	77.52	77.12	76.73		-50
-40	84.27	83.87	83.48	83.08	82.69	82.29	81.89	81.50	81.10	80.70		-40
-30	88.22	87.83	87.43	87.04	86.64	86.25	85.85	85.46	85.06	84.67		-30
-20	92.16	91.77	91.37	90.98	90.59	90.19	89.80	89.40	89.01	88.62		-20
-10	96.09	95.69	95.30	94.91	94.52	94.12	93.73	93.34	92.95	92.55		-10
0	100.00	99.61	99.22	98.83	98.44	98.04	97.65	97.26	96.87	96.48		0
t(°C)	0	1	2	3	4	5	6	7	8	9	t(°C)	
0	100.00	100.39	100.78	101.17	101.56	101.95	102.34	102.73	103.12	103.51		0
10	103.90	104.29	104.68	105.07	105.46	105.85	106.24	106.63	107.02	107.40		10
20	107.79	108.18	108.57	108.96	109.35	109.73	110.12	110.51	110.90	111.29		20
30	111.67	112.06	112.45	112.83	113.22	113.61	114.00	114.38	114.77	115.15		30
40	115.54	115.93	116.31	116.70	117.08	117.47	117.86	118.24	118.63	119.01		40
50	119.40	119.78	120.17	120.55	120.94	121.32	121.71	122.09	122.47	122.86		50
60	123.24	123.63	124.01	124.39	124.78	125.16	125.54	125.93	126.31	126.69		60
70	127.08	127.46	127.84	128.22	128.61	128.99	129.37	129.75	130.13	130.52		70
80	130.90	131.28	131.66	132.04	132.42	132.80	133.18	133.57	133.95	134.33		80
90	134.71	135.09	135.47	135.85	136.23	136.61	136.99	137.37	137.75	138.13		90
100	138.51	138.88	139.26	139.64	140.02	140.40	140.78	141.16	141.54	141.91		100
110	142.29	142.67	143.05	143.43	143.80	144.18	144.56	144.94	145.31	145.69		110
120	146.07	146.44	146.82	147.20	147.57	147.95	148.33	148.70	149.08	149.46		120
130	149.83	150.21	150.58	150.96	151.33	151.71	152.08	152.46	152.83	153.21		130
140	153.58	153.96	154.33	154.71	155.08	155.46	155.83	156.20	156.58	156.95		140
150	157.33	157.70	158.07	158.45	158.82	159.19	159.56	159.94	160.31	160.68		150
160	161.05	161.43	161.80	162.17	162.54	162.91	163.29	163.66	164.03	164.40		160
170	164.77	165.14	165.51	165.89	166.26	166.63	167.00	167.37	167.74	168.11		170
180	168.48	168.85	169.22	169.59	169.96	170.33	170.70	171.07	171.43	171.80		180
190	172.17	172.54	172.91	173.28	173.65	174.02	174.38	174.75	175.12	175.49		190
200	175.86	176.22	176.59	176.96	177.33	177.69	178.06	178.43	178.79	179.16		200
210	179.53	179.89	180.26	180.63	180.99	181.36	181.72	182.09	182.46	182.82		210
220	183.19	183.55	183.92	184.28	184.65	185.01	185.38	185.74	186.11	186.47		220
230	186.84	187.20	187.56	187.93	188.29	188.66	189.02	189.38	189.75	190.11		230
240	190.47	190.84	191.20	191.56	191.92	192.29	192.65	193.01	193.37	193.74		240
250	194.10	194.46	194.82	195.18	195.55	195.91	196.27	196.63	196.99	197.35		250
260	197.71	198.07	198.43	198.79	199.15	199.51	199.87	200.23	200.59	200.95		260
270	201.31	201.67	202.03	202.39	202.75	203.11	203.47	203.83	204.19	204.55		270
280	204.90	205.26	205.62	205.98	206.34	206.70	207.05	207.41	207.77	208.13		280
290	208.48	208.84	209.20	209.56	209.91	210.27	210.63	210.98	211.34	211.70		290
300	212.05	212.41	212.76	213.12	213.48	213.83	214.19	214.54	214.90	215.25		300
310	215.61	215.96	216.32	216.67	217.03	217.38	217.74	218.09	218.44	218.80		310
320	219.15	219.51	219.86	220.21	220.57	220.92	221.27	221.63	221.98	222.33		320

Table 25 PT100 Temperature/Resistance Index Table

t(°C)	Resistance at temperature t(Ω)										t(°C)
	0	1	2	3	4	5	6	7	8	9	
330	222.68	223.04	223.39	223.74	224.09	224.45	224.80	225.15	225.50	225.85	330
340	226.21	226.56	226.91	227.26	227.61	227.96	228.31	228.66	229.02	229.37	340
350	229.72	230.07	230.42	230.77	231.12	231.47	231.82	232.17	232.52	232.87	350
360	233.21	233.56	233.91	234.26	234.61	234.96	235.31	235.66	236.00	236.35	360
370	236.70	237.05	237.40	237.74	238.09	238.44	238.79	239.13	239.48	239.83	370
380	240.18	240.52	240.87	241.22	241.56	241.91	242.26	242.60	242.95	243.29	380
390	243.64	243.99	244.33	244.68	245.02	245.37	245.71	246.06	246.40	246.75	390
400	247.09	247.44	247.78	248.13	248.47	248.81	249.16	249.50	249.85	250.19	400
410	250.53	250.88	251.22	251.56	251.91	252.25	252.59	252.93	253.28	253.62	410
420	253.96	254.30	254.65	254.99	255.33	255.67	256.01	256.35	256.70	257.04	420
430	257.38	257.72	258.06	258.40	258.74	259.08	259.42	259.76	260.10	260.44	430
440	260.78	261.12	261.46	261.80	262.14	262.48	262.82	263.16	263.50	263.84	440
450	264.18	264.52	264.86	265.20	265.53	265.87	266.21	266.55	266.89	267.22	450
460	267.56	267.90	268.24	268.57	268.91	269.25	269.59	269.92	270.26	270.60	460
470	270.93	271.27	271.61	271.94	272.28	272.61	272.95	273.29	273.62	273.96	470
480	274.29	274.63	274.96	275.30	275.63	275.97	276.30	276.64	276.97	277.31	480
490	277.64	277.98	278.31	278.64	278.98	279.31	279.64	279.98	280.31	280.64	490
500	280.98	281.31	281.64	281.98	282.31	282.64	282.97	283.31	283.64	283.97	500
510	284.30	284.63	284.97	285.30	285.63	285.96	286.29	286.62	286.95	287.29	510
520	287.62	287.95	288.28	288.61	288.94	289.27	289.60	289.93	290.26	290.59	520
530	290.92	291.25	291.58	291.91	292.24	292.56	292.89	293.22	293.55	293.88	530
540	294.21	294.54	294.86	295.19	295.52	295.85	296.18	296.50	296.83	297.16	540
550	297.49	297.81	298.14	298.47	298.80	299.12	299.45	299.78	300.10	300.43	550
560	300.75	301.08	301.41	301.73	302.06	302.38	302.71	303.03	303.36	303.69	560
570	304.01	304.34	304.66	304.98	305.31	305.63	305.96	306.28	306.61	306.93	570
580	307.25	307.58	307.90	308.23	308.55	308.87	309.20	309.52	309.84	310.16	580
590	310.49	310.81	311.13	311.45	311.78	312.10	312.42	312.74	313.06	313.39	590
600	313.71	314.03	314.35	314.67	314.99	315.31	315.64	315.96	316.28	316.60	600
610	316.92	317.24	317.56	317.88	318.20	318.52	318.84	319.16	319.48	319.80	610
620	320.12	320.44	320.76	321.08	321.40	321.72	322.04	322.36	322.68	323.00	620
630	323.30	323.62	323.94	324.26	324.58	324.90	325.22	325.54	325.86	326.18	630
640	326.48	326.80	327.12	327.44	327.76	328.08	328.40	328.72	329.04	329.36	640
650	329.64	329.96	330.28	330.60	330.92	331.24	331.56	331.88	332.20	332.52	650
660	332.79	333.11	333.43	333.75	334.07	334.39	334.71	335.03	335.35	335.67	660
670	335.93	336.25	336.57	336.89	337.21	337.53	337.85	338.17	338.49	338.81	670
680	339.06	339.38	339.70	340.02	340.34	340.66	340.98	341.30	341.62	341.94	680
690	342.18	342.50	342.82	343.14	343.46	343.78	344.10	344.42	344.74	345.06	690
700	345.28	345.60	345.92	346.24	346.56	346.88	347.20	347.52	347.84	348.16	700
710	348.38	348.70	349.02	349.34	349.66	349.98	350.30	350.62	350.94	351.26	710
720	351.46	351.78	352.10	352.42	352.74	353.06	353.38	353.70	354.02	354.34	720
730	354.53	354.85	355.17	355.49	355.81	356.13	356.45	356.77	357.09	357.41	730
740	357.59	357.91	358.23	358.55	358.87	359.19	359.51	359.83	360.15	360.47	740
750	360.64	360.96	361.28	361.60	361.92	362.24	362.56	362.88	363.20	363.52	750
760	363.67	363.99	364.31	364.63	364.95	365.27	365.59	365.91	366.23	366.55	760
770	366.70	367.02	367.34	367.66	367.98	368.30	368.62	368.94	369.26	369.58	770
780	369.71	370.03	370.35	370.67	370.99	371.31	371.63	371.95	372.27	372.59	780
790	372.71	373.03	373.35	373.67	373.99	374.31	374.63	374.95	375.27	375.59	790
800	375.70	376.02	376.34	376.66	376.98	377.30	377.62	377.94	378.26	378.58	800
810	378.68	379.00	379.32	379.64	379.96	380.28	380.60	380.92	381.24	381.56	810
820	381.65	381.97	382.29	382.61	382.93	383.25	383.57	383.89	384.21	384.53	820
830	384.60	384.92	385.24	385.56	385.88	386.20	386.52	386.84	387.16	387.48	830
840	387.55	387.87	388.19	388.51	388.83	389.15	389.47	389.79	390.11	390.43	840
850	390.48										850

Table 26 PT100 Temperature/Resistance Index Table (continued from the previous table)

## **9. About JYTEK**

### **9.1 JYTEK China**

Founded in June, 2016, JYTEK China is a leading Chinese test & measurement company, providing complete software and hardware products for the test and measurement industry. The company has evolved from re-branding and reselling PXI(e) and DAQ products to a fully-fledged product company. The company offers complete lines of PXI, DAQ, USB products. More importantly, JYTEK has been promoting open-sourced based ecosystem and offers complete software products. Presently, JYTEK is focused on the Chinese market. Our Shanghai headquarters and production service center have regular stocks to ensure timely supply; we also have R&D centers in Xi'an and Chongqing. We also have highly trained direct technical sales representatives in Shanghai, Beijing, Tianjin, Xi'an, Chengdu, Nanjing, Wuhan, Guangdong, Haerbin, and Changchun. We also have many partners who provide system level support in various cities.

### **9.2 JYTEK Software Platform**

JYTEK has developed a complete software platform, SeeSharp Platform, for the test and measurement applications. We leverage the open sources communities to provide the software tools. Our platform software is also open sourced and is free, thus lowering the cost of tests for our customers. We are the only domestic vendor to offer complete commercial software and hardware tools.

### **9.3 JYTEK Warranty and Support Services**

With our complete software and hardware products, JYTEK is able to provide technical and sales services to wide range of applications and customers. In most cases, our products are backed by a 1-year warranty. For technical consultation, pre-sale and after-sales support, please contact JYTEK of your country.

## 10.Statement

The hardware and software products described in this manual are provided by JYTEK China, or JYTEK in short.

This manual provides the product review, quick start, some driver interface explanation for JYTEK JY-6311 Series family of multi-function data acquisition boards. The manual is copyrighted by JYTEK.

No warranty is given as to any implied warranties, express or implied, including any purpose or non-infringement of intellectual property rights, unless such disclaimer is legally invalid. JYTEK is not responsible for any incidental or consequential damages related to performance or use of this manual.

The information contained in this manual is subject to change without notice.

While we try to keep this manual up to date, there are factors beyond our control that may affect the accuracy of the manual. Please check the latest manual and product information from our website.

Shanghai Jianyi Technology Co., Ltd.

Address: Room 201, Building 3, NO.300 Fangchun Road, Shanghai.

Post Code: 201203

Tel: 021-5047 5899

Website: [www.jytek.com](http://www.jytek.com)